

RESCUE•MASTER

Unique Winching System for Rescue Services

FEATURES INCLUDE

- Fully compliant with EN 14492-1 regulations.
- Unique positioning of the winch ensures the wire rope wraps onto the drum without bunching due to the minimum approach angle of the rope to the drum (fleet angle).
- The rear mounted winch is conveniently positioned for easy access to the free spool clutch and for maintenance purposes. The rope is also visible whilst wrapping on the drum. Space is provided for the wire rope to run forward and then return to the rear between the body sub-frame members.
- No reeving is required to achieve pulls from the front or rear. The wire rope can be spooled off the winch drum when the hook is taken to the recovery by simply releasing the free spool clutch on the winch. (Mechanical or hydraulic free spool release is available).
- The rear winching action always incorporates the snatch block thus doubling the winch capacity and pulling power.
- The front rotator enables the wire rope to be pulled at an angle both horizontally and vertically to the rescue vehicle.

BHW Group has been a supplier to the Fire Rescue Service for over 25 years. Their range of electric and hydraulic winches is extensive, and includes overload protection and other safety features required by the specialist nature of this work. In addition to the **RESCUE•MASTER** winching system illustrated, BHW provides winches and all ancillary equipment necessary for front bumper mounting.

All machines are rated 2:1 factor of safety in line with MOD requirements BS7901.

The BHW **RESCUE•MASTER** winching system has been developed for use by the Rescue Services on rapid intervention vehicles where maximum flexibility is required. One hydraulic machine provides front and rear winching facility on rescue vehicles, giving up to 9.25 tonnes pulling capacity.

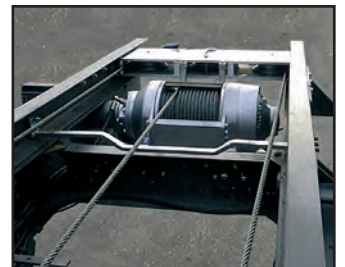

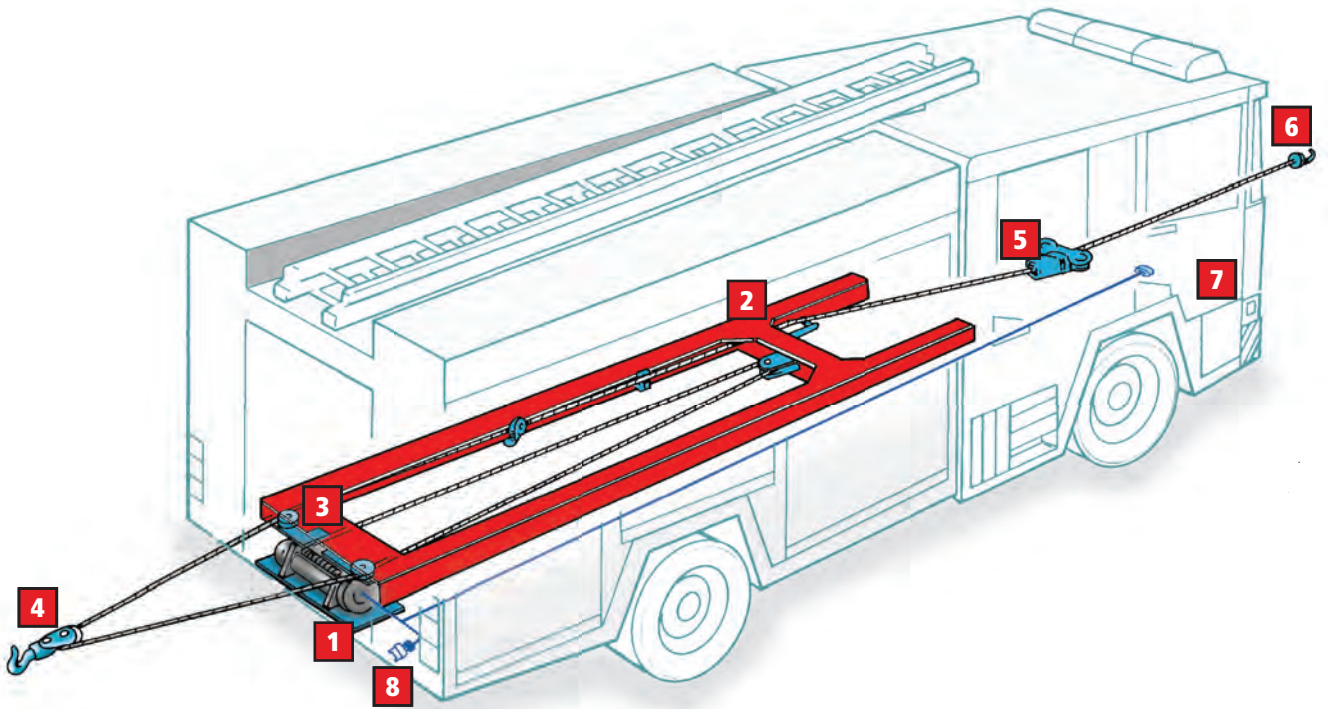

- 1** Low profile hydraulic winch choice: 3.2, and 5.0 capacities. (Conforms to BS7901).
- 2** Return sheave assembly.
- 3** Return sheave assembly and snatch block housing.
- 4** Heavy rear recovery snatch block with safety hook.
- 5** Front fairlead.
- 6** Wire rope and hook for front end recovery.
- 7** Plug in wanderlead position (front) with emergency stop.
- 8** Plug in wanderlead position (rear) with emergency stop.

Rear winch position provides complete accessibility for:

- (a)** ease of control of the free spool clutch
- (b)** ease of maintenance and
- (c)** clear operator view of the winch.

Training courses available and full after sales back up service provided.



OPTIONAL EXTRA

BHW FM•CONNECT REMOTE CONTROL SYSTEM – CONTACT SALES FOR DETAILS.

CONTROL

An electric valve is incorporated enabling a remote wanderlead control to be plugged in at both winching locations. The electric valve can also incorporate a manual lever for very fine control.

A pressure relief valve protects the system against overload.

SYSTEM INCLUDES

- A selection of hydraulic winches to provide:
 - (a)** line pull
 - (b)** rope capacity
 - (c)** line speed, to match vehicles and application.
- Front return sheave block assembly.
- Rear return sheave block and snatch block housing.
- Snatch block.
- Front rotator fairlead and other sheave wheels.
- Wire rope and hook.
- Pneumatic or hydraulic remote free spool clutch release.
- Electric control valve with full wiring harness and wanderlead control.
- PTO/Pumps, hydraulic oil reservoir tanks and cable tensioner can also be provided.
- Emergency stop systems.

Bushey Hall Winchmaster sales@bhwwgroup.co.uk www.bhwwgroup.com

Southern Office: Lismirrane Industrial Park, Elstree Road, Elstree, Herts, WD6 3EE Tel: +44 (0)20 8953 6050 Fax: +44 (0)20 8207 5308

Northern Office: 6 South Orbital Trading Park, Hedon Road, Hull, East Yorkshire, HU9 1NJ Tel: +44 (0)1482 223 663 Fax: +44 (0)1482 218 285

Bushey Hall Winchmaster is a division of BHW Group Limited. Registered in England No. 1342461



CERT. No. 1769